

C  
3

# Cable Trolleys and Festoon Systems

## Product Catalogue

Technical Information  
Component Specification



*NIKO ... Quality in Motion*

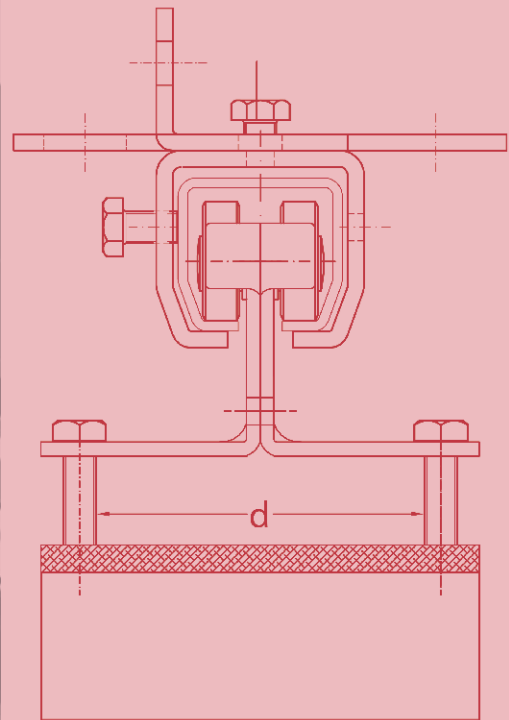

[www.niko.eu.com](http://www.niko.eu.com)

**HELM HELLAS** S.A.

MANUFACTURERS OF SLIDING DOOR FITTINGS  
AND CONVEYOR SYSTEMS



## Company Profile

Established in 1972, Helm Hellas S.A. is focused on designing developing, producing and marketing high quality sliding door fittings and overhead conveyor systems at the right price. Over 90 % of our products are exported to more than 60 countries worldwide with offices and warehouses in 7 countries worldwide.

Our program range includes more than 2.000 different assemblies & components. Our team of highly qualified engineers are continually working to improve our current product portofolio & extend it according to market requirements.

Helm Hellas S.A. enforces a continuous quality control program and is certified according to ISO:9001 and ISO:14000.



# Index

Introduction	Page	4
Calculation of distance between supports	Page	5
Application Photos	Page	6-7
Component Specifications	Page	8-17
Track Profiles	Page	8
Support Bracket & Support Joints	Page	9-11
Cable Trolleys	Page	12-16
Stoppers	Page	17
Notes	Page	18

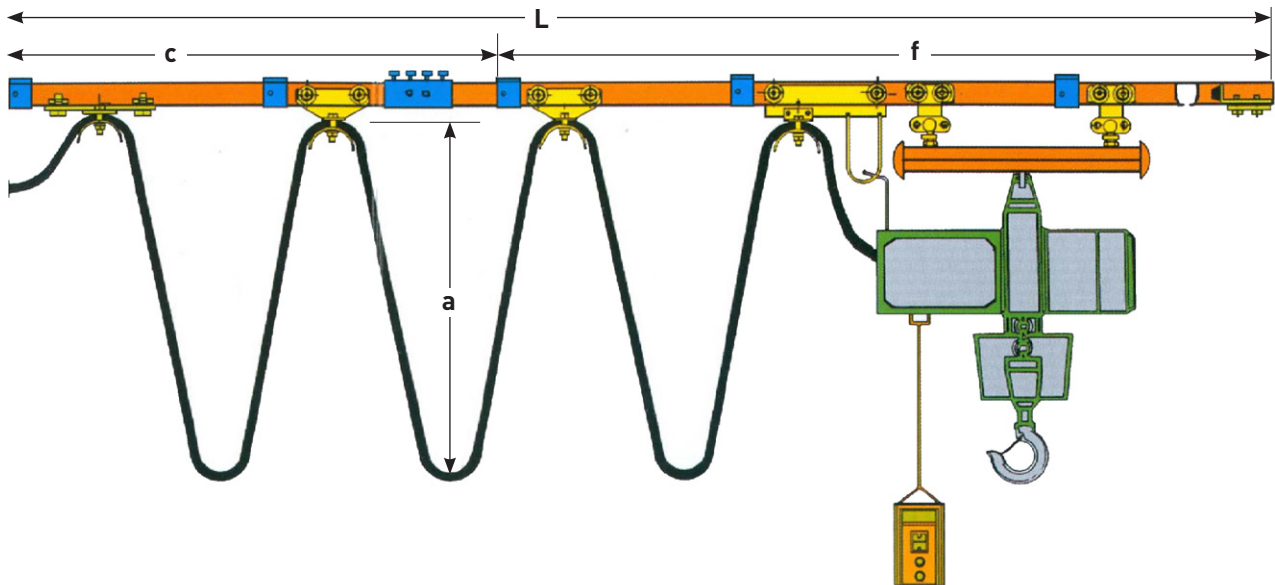

## Calculation of the Track Length ( $L=c+f$ ) and number of cable trolleys

The length of the track  $L$  is determined by adding the length of movement  $f$  to the closed parking distance of trolleys  $c$  (Refer to corresponding table for the dimension of the cable trolleys width). The number of cable trolleys  $n$  depends on the length of travel and on the required loop depth of cable  $a$ . The loop depth is governed by the available height between the track and any obstruction or by clients specification. Normally the loop depth is between 0,7 m to 1 m.

### Example:

Track length  $L= 16$  m, cable loop depth  $a= 0,8$  m  
 Distance between the trolleys  $= 2 \times a = 2 \times 0,8 = 1,6$  m  
 Number of the cable trolleys  $n = 16 \text{ m} / 1,6 \text{ m} = 10$  trolleys, one of them being a towing trolley.  
 The cable section depends on the necessary power supply. Large cable sections have unfavorable bending properties. In this case we recommend to distribute among many cables of small section.  
 For round cables:  $d$  min = 8 mm,  $d$  max = 60 mm (refer to table).  
 For flat cables:  $(dxc)$  max = 200 x 50 mm (refer to table).  
 For installations with a high speeds of motion (over 2 m per second) we recommend to use chains, in order to protect the cables.

NIKO Profile	Cable trolley's speed of motion
21.000	0,1-1m/sec
23.000	1,1 -2m/sec
24.000	2,1 -3m/sec
25.000	over 3m/sec

# Calculation of distance between supports

## Dimension "A"

The maximum distance "A" of the track supports can be determined from the diagram detailed below, according to the track profile selected and the required load P. Refer to example. Load "P" is the maximum cable weight, achieved during the gathering of the trolleys between two track supports. It depends on the loop depth of the cable as well as on the width of the cable trolleys. Usually, every 1 - 2.5 m there is one track support, while the supports at the beginning of the cable are installed closer to each other.

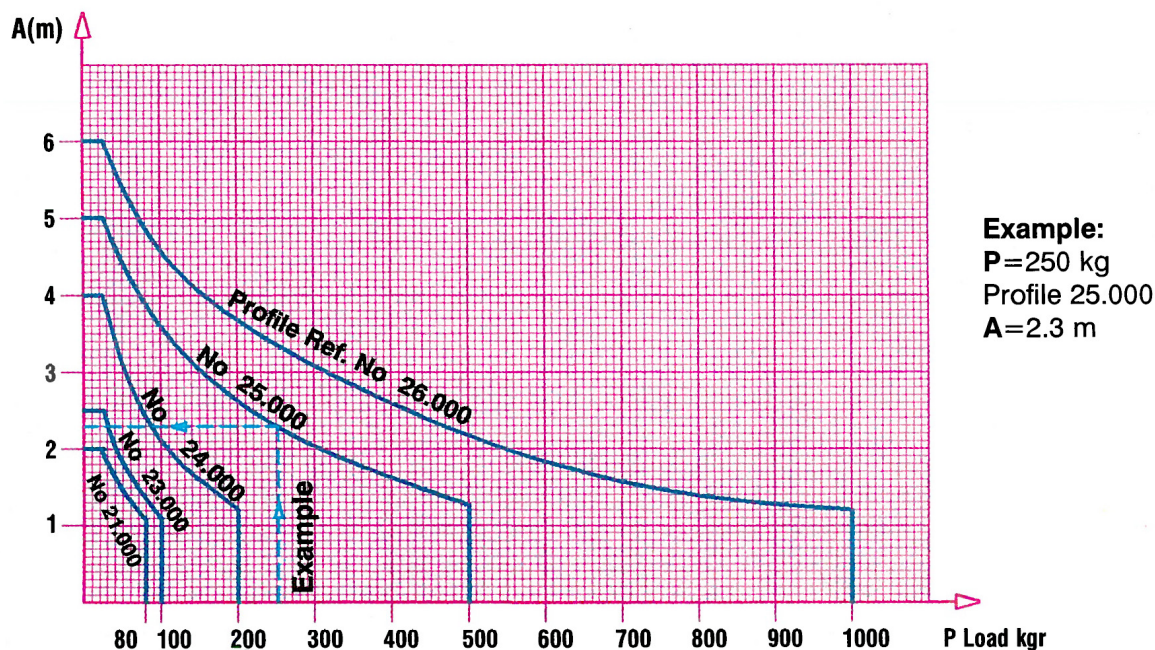

CABLE TROLLEYS AND FESTOON SYSTEMS

NIKO Profile No.	21.000	23.000	24.000	25.000	26.000
Max load /m	80kg	100kg	200kg	500kg	1000kg
0,1-1m /sec	20kg	30kg	40kg	80kg	100kg

# Application Photos

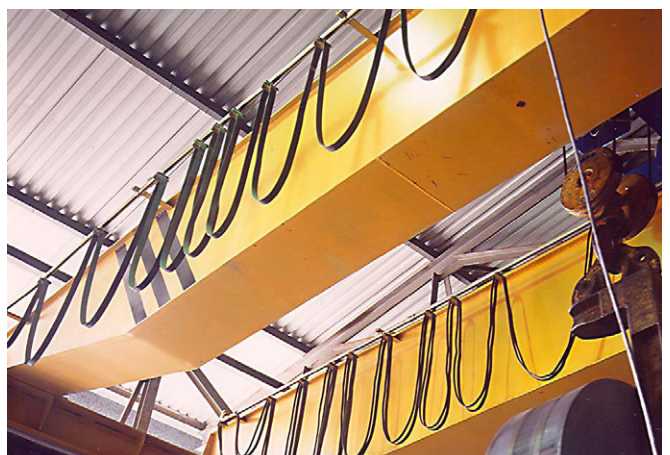
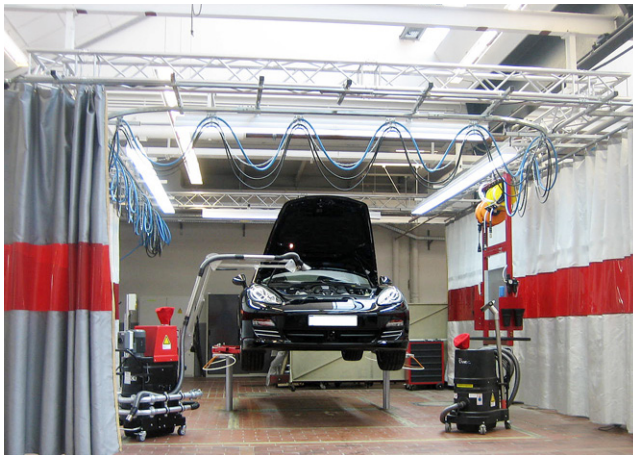

CABLE TROLLEYS  
AND FESTOON SYSTEMS

# Application Photos



CABLE TROLLEYS  
AND FESTOON SYSTEMS

# Component Specifications

## NIKO Track Profiles

Our wide range of 6 Track profile sizes can accommodate loads up to 2.000 kg. The NIKO enclosed track tapered design allows correct alignment of the trolleys and reduces the possibility of dust build up. This ensures the smooth running of the trolleys and the long life of the crane. NIKO conveyors require only 1-4% force of the weight being lifted in order to operate. For use in aggressive environments we can also offer conveyors in stainless steel grade 304.

NIKO Profile No.	Dimensions			
	h (mm)	b (mm)	d (mm)	s (mm)
21.000	28	30	8	1,75
21.050 stainless steel	28	30	8	1,75
23.000	35,00	40,00	11,00	2,75
23.050 stainless steel	35,00	40,00	11,00	2,75
24.000	43,50	48,50	15,00	3,20
24.050 stainless steel	43,50	48,50	15,00	3,20
25.000	60,00	65,00	18,00	3,60
25.050 stainless steel	60,00	65,00	18,00	3,60
26.000	75,00	80,00	22,00	4,50
27.000	110,00	90,00	25,00	6,50

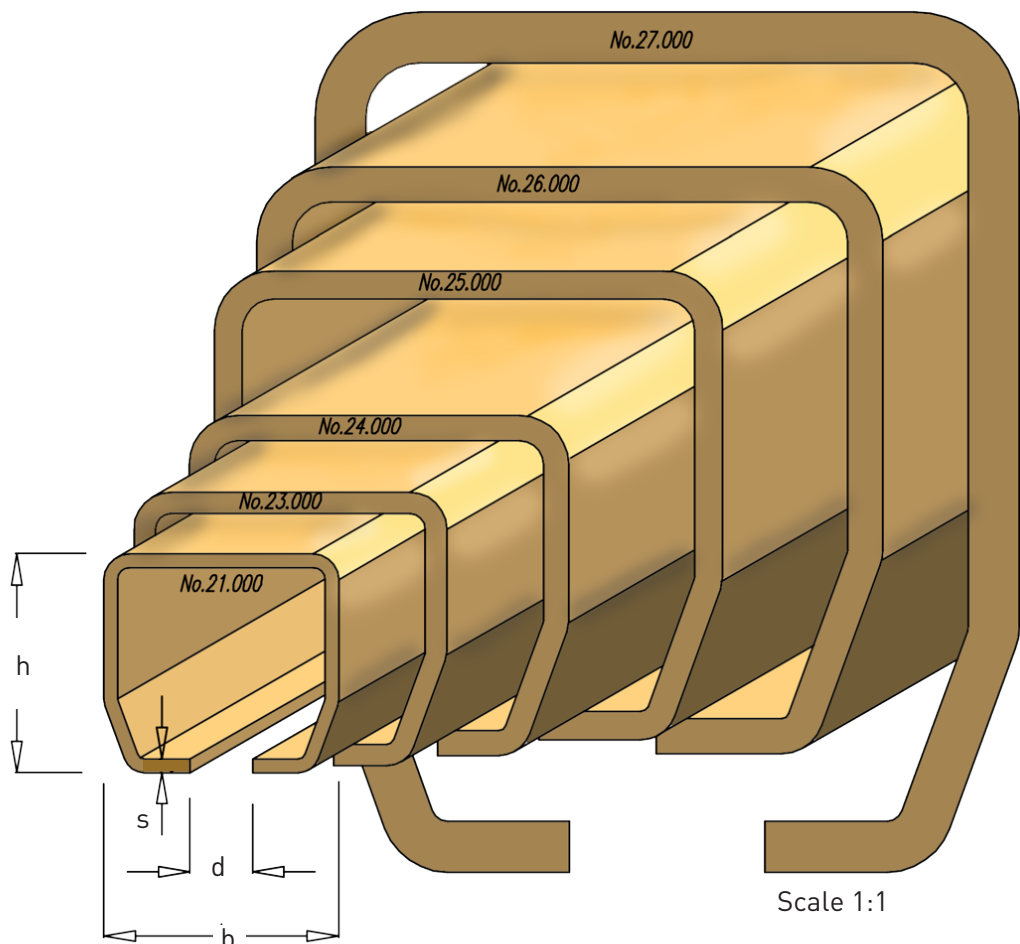



# Support Bracket

**.B00/.B50**

This bracket can be used and adapted for specific applications where standard supports are unsuitable.

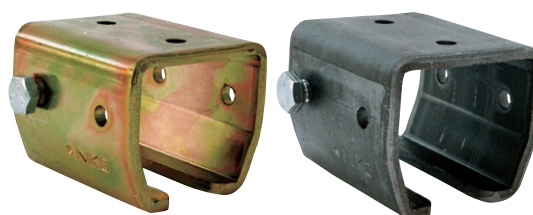

NIKO Profile No.	21.000	23.000	24.000	25.000	26.000	27.000
Support bracket No. Zinc plated	21.B00	23.B00	24.B00	25.B00	26.B00	27.B00
Support bracket No. Black	21.B50	23.B50	24.B50	25.B50	26.B50	27.B50
L (mm)	40	55	68	90	110	120
b (mm)	38	49	60	80	100	114
h (mm)	36	45	54	75	93	134
s (mm)	3	4	4,5	6	8	10

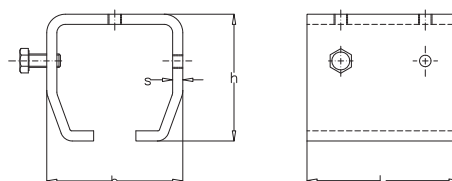

# Splice Joint

**.B49**

The track sections are joined using the track joint by tightening the top screws first then aligning the profiles by means of the side screws.



NIKO Profile No.	21.000	23.000	24.000	25.000	26.000	27.000
Splice joint No.	21.B49	23.B49	24.B49	25.B49	26.B49	27.B49
L (mm)	85	120	150	180	200	250
h (mm)	36	45	54	75	93	134
b (mm)	38	50	60	80	100	118
s (mm)	3	4	4,5	6	8	10

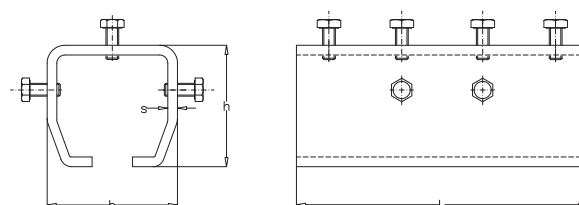

# Ceiling Support Bracket

**.B02**

This bracket is designed for bolting direct to overhead steelwork or ceiling.

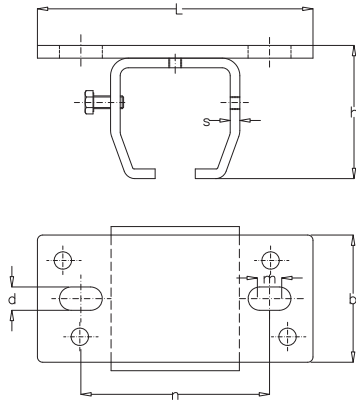
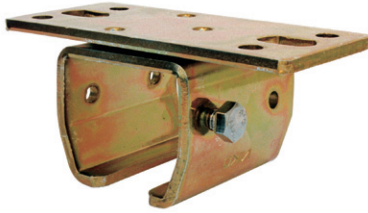

NIKO Profile No.	21.000	23.000	24.000	25.000	26.000	27.000
Support bracket No.	21.B02	23.B02	24.B02	25.B02	26.B02	27.B02
L (mm)	88	115	130	170	210	260
h (mm)	39	51	60	83	103	146
b (mm)	40	50	60	80	100	118
d (mm)	8	11	13	17	22	22
n (mm)	63	80	94	124	148	178,5
s (mm)	3	4	4,5	6	8	10
m (mm)	7	8	8	10	12	23,5

# Wall Support Bracket

**.B01**

This kind of support is used for mounting the track directly on to a wall as well as for other constructions with mounting bolts.

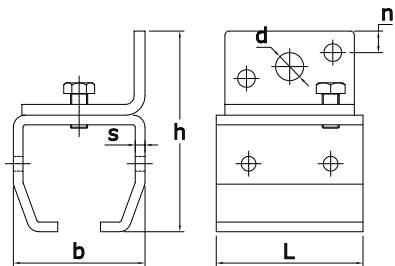

NIKO Profile No.	21.000	23.000	24.000	25.000	26.000	27.000
Wall support bracket No.	21.B01	23.B01	24.B01	25.B01	26.B01	27.B01
b (mm)	38	49	60	80	100	118
h (mm)	60	76	95	125	155	210
L (mm)	40	55	68	90	110	120
n (mm)	10	13	16,5	18	25	32
d (mm)	8Φ	11Φ	13Φ	17Φ	22Φ	26Φ
s (mm)	3	4	4,5	6	8	10

# Split Support Bracket

.B03

This bracket is generally used for variable height configurations.

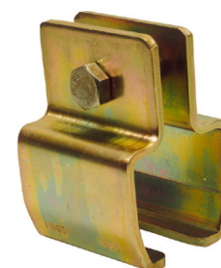

NIKO Profile No.	21.000	23.000	24.000	25.000	26.000	27.000
Support bracket No.	21.B03	23.B03	24.B03	25.B03	26.B03	27.B03
B (mm)	36	48	56,5	77	96	110
H (mm)	64,5	80	88	132	150	180
L (mm)	40	50	50	90	110	120
h (mm)	49	59	70	94	111	148
s (mm)	3	4	4	6	8	10
e (mm)	6	8	8	10	10	15
d (mm)	M10	M12	M12	M16	M16	M16

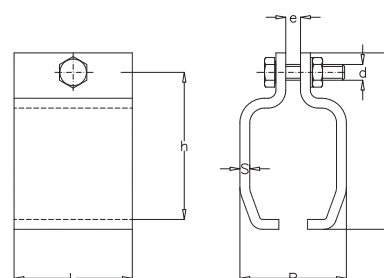

# Split Suspension Bracket

.B08/.B26

This bracket is used for mounting directly to the underside flange of a parallel I beam.

NIKO Profile No.	23.000	24.000	25.000	26.000	27.000
Dimension a in mm.	25	25	42	46	66
Dimension b in mm.	34	34	56	63	95
Dimension c in mm.	35	44	60	75	110
Dimension d in mm.	9 Φ	9 Φ	17 Φ	17 Φ	17 Φ
Screw type	M8x30	M8x30	M16x50	M16x50	M16x50
Material	50x4	50x4	90x6	110x8	120x10
<b>Split Suspension Bracket Joist IPN DIN 1025</b>					
For IPN 80x42 (IPE 80)	23.B08	24.B08			
For IPN 100x50 (IPE 80)	23.B10	24.B10	25.B10		
For IPN 120x58 (IPE 100)	23.B12	24.B12	25.B12		
For IPN 140x66 (IPE 120)	23.B14	24.B14	24.B14		
For IPN 160x74 (IPE 140)		24.B16	25.B16	26.B16	
For IPN 180x82 (IPE 160)		24.B18	25.B18	26.B18	
For IPN 200x90 (IPE 180)		24.B20	25.B20	26.B20	27.B20
For IPN 220x98 (IPE 200)			25.B22	26.B22	27.B22
For IPN 240x106 (IPE 220)			25.B24	26.B24	27.B24
For IPN 260x113 (IPE 240)			25.B26	26.B26	27.B26

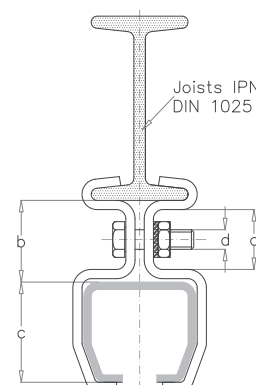

CABLE TROLLEYS AND FESTOON SYSTEMS

# Flat Cable Trolley

## .L10/.L11

Flat cable trolleys are suitable for the transport of flat cables of various dimensions (refer to table).

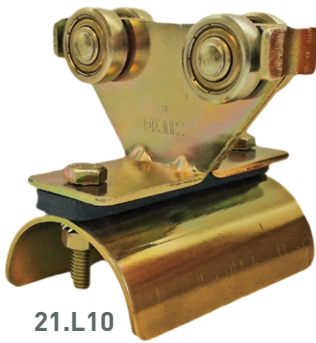

21.L10

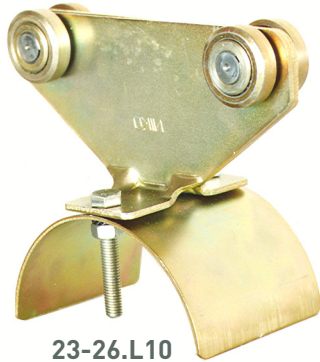

23-26.L10

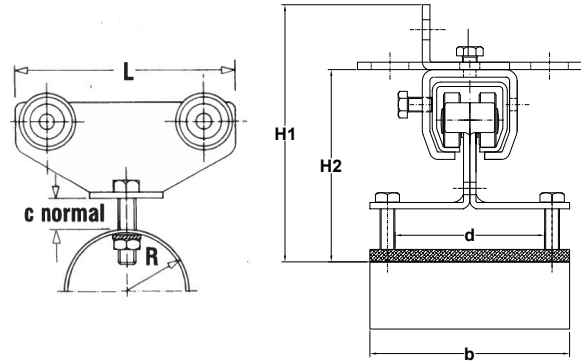

NIKO Profile No.	21.000	23.000		24.000		25.000	26.000
Item Ref.	21.L10	23.L10	23.L11	24.L10	21.L11	25.L10	26.L10
Cable max (mm)	55X20	55X30	100X30	55X40	100X40	150X50	200X50
L (mm)	77	130	130	160	160	220	220
H1 (mm)	94	140	140	175	175	214	258
H2 (mm)	74	115	115	140	140	172	198
b (mm)	80	80	140	80	140	190	240
c (mm)	12	20	20	24	24	38	38
d (mm)	55	55	100	55	100	150	200
R (mm)	25	45	45	55	55	70	70

CABLE TROLLEYS AND FESTOON SYSTEMS

# Flat Cable Towing Trolley

## .M10/.M11

This trolley is pulled along by means of a towing arm fitted to the travelling device and inserted into the stirrup section of the trolley. It cannot be used on curved tracks.

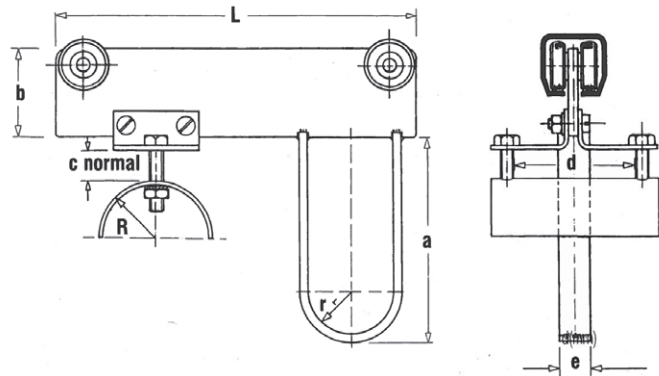
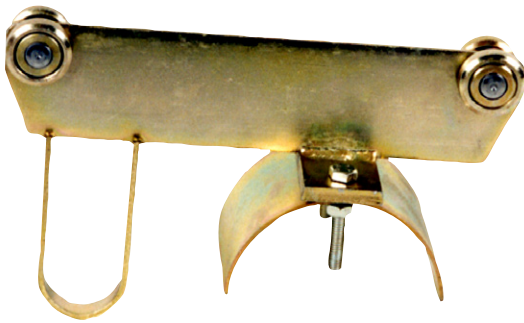

NIKO Profile No.	21.000	23.000		24.000		25.000	26.000
Item Ref.	21.M10	23.M10	23.M11	24.M10	21.M11	25.M10	26.M10
Cable max (mm)	55X20	55X30	100X30	55X40	100X40	150X50	200X50
L (mm)	165	230	230	260	260	360	360
a (mm)	94	94	94	94	94	156	156
b (mm)	40	60	60	60	60	90	110
c (mm)	12	20	20	24	24	38	38
d (mm)	55	55	100	55	100	150	200
e (mm)	15	15	15	15	15	20	20
R (mm)	25	45	45	55	55	70	70
r (mm)	20	20	20	20	20	40	40

# Flat Cable end Clamp

.K10/.K11

The flat cable end clamps are installed at the end of the conveyor system and guarantee the stability of the cable from the point of electric or hydraulic supply to the driven cable trolley.

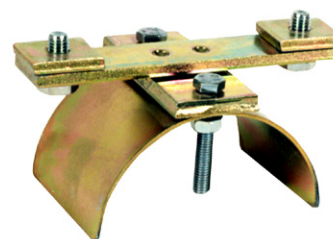
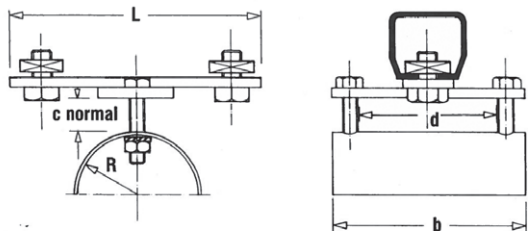

NIKO Profile No.	21.000		23.000		24.000		25.000	26.000
Item Ref.	21.K10	23.K10	23.K11	24.K10	24.K11	25.K10	26.K10	
Cable max (mm)	55X20	55X30	100X30	55X40	100X40	150X50	200X50	
L (mm)	100	150	150	180	180	210	210	
b (mm)	80	80	140	80	140	190	240	
c (mm)	12	20	20	24	24	38	38	
d (mm)	55	55	100	55	100	150	200	
R (mm)	25	45	45	55	55	70	70	

# Round Cable or Hose Trolley

.L15-.L43

These trolleys are suitable for the transport of flexible cables and hoses of various dimensions.

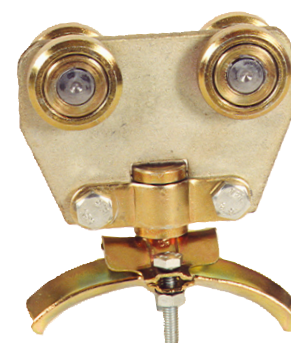
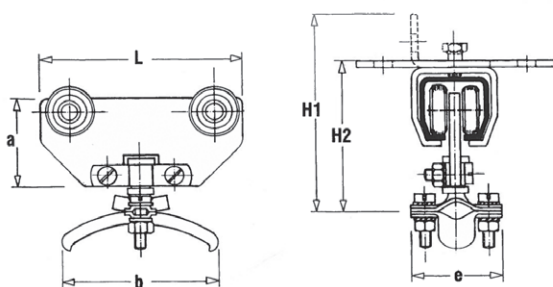

NIKO Profile No.	21.000		23.000				24.000			
Item Ref.	21.L15	21.L24	23.L15	23.L24	23.L32	23.L43	24.L15	24.L24	24.L32	24.L43
Cable (mm)	8-15	16-24	8-15	16-24	25-32	33-43	8-15	16-24	25-32	33-43
H1 (mm)	91	96	116	121	123	130	140	142	148	158
H2 (mm)	68	73	90	95	97	106	104	106	112	122
L (mm)	90	90	100	100	150	150	100	100	150	150
a (mm)	40	40	60	60	60	60	70	70	70	70
b (mm)	70	100	70	100	142	175	70	100	142	175
e (mm)	40	54	40	54	83	108	40	54	83	108

CABLE TROLLEYS  
AND FESTOON SYSTEMS

## Round Cable or Hose Towing Trolley .M15-.M43

This trolley is pulled along by means of a towing arm fitted to the travelling device and inserted into the stirrup section of the trolley. It cannot be used on the curved tracks.

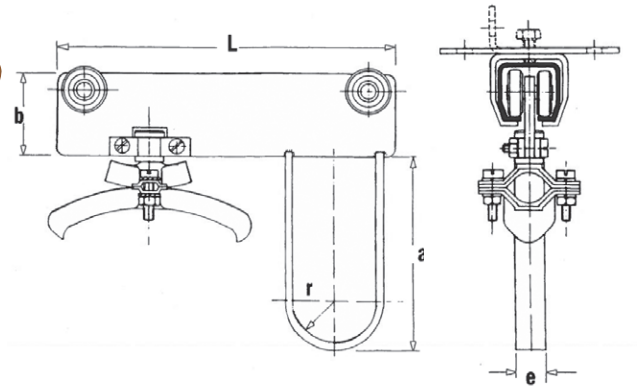
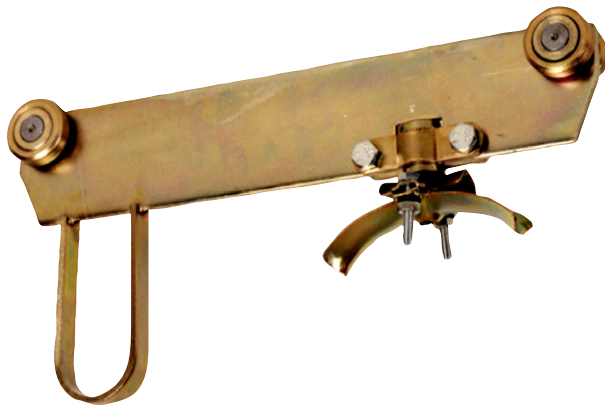

NIKO Profile No.	21.000		23.000				24.000			
Item Ref.	21.M15	21.M24	23.M15	23.M24	23.M32	23.M43	24.M15	24.M24	24.M32	24.M43
Cable (mm)	8-15	16-24	8-15	16-24	25-32	33-43	8-15	16-24	25-32	33-43
L (mm)	165	165	230	230	230	310	230	230	310	310
a (mm)	94	94	94	94	94	94	94	94	94	94
b (mm)	40	40	60	60	60	60	70	70	70	70
e (mm)	15	15	15	15	15	15	15	15	15	15
r (mm)	20	20	20	20	20	20	20	20	20	20

## Round Cable or Hose end Clamp .K15-.K43

This round cable end clamp is installed at the end of the conveyor system and guarantees the stability of the cable from the point of electric or hydraulic supply to the driven cable trolley.

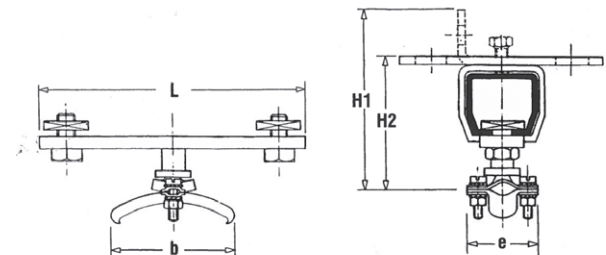
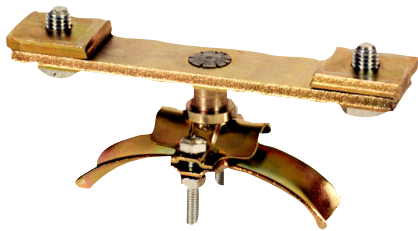

NIKO Profile No.	21.000		23.000				24.000			
Item Ref.	21.K15	21.K24	23.K15	23.K24	23.K32	23.K43	24.K15	24.K24	24.K32	24.K43
Cable (mm)	8-15	16-24	8-15	16-24	25-32	33-43	8-15	16-24	25-32	33-43
L (mm)	100	100	150	150	150	150	150	150	150	150
H1 (mm)	73	78	95	100	105	115	114	119	125	135
H2 (mm)	50	55	69	74	79	89	79	84	90	100
e (mm)	40	54	40	54	83	108	40	54	83	108
b (mm)	70	100	70	100	142	175	70	100	142	175

# Individual Round Cable or Hose Clamp .N15-.N43

Several cable clamps of equal or varying diameters can be placed in round cable trolleys. Clamps may be pre-assembled or subsequently added.

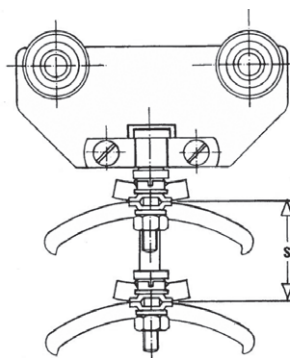
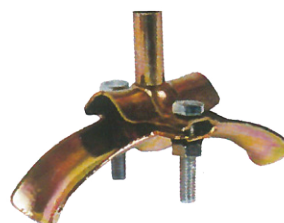

CABLE TROLLEYS  
AND FESTOON SYSTEMS

NIKO Profile No.	21.000				23.000			24.000			
Item Ref.	21.N15	21.N24	23.N15	23.N24	23.N32	23.N43	24.N15	24.N24	24.N32	24.N43	
Cable (mm)	8-15	16-24	8-15	16-24	25-32	33-43	8-15	16-24	25-32	33-43	
s (mm)	32	50	32	50	70	90	32	50	70	90	

## Cable Trolley (nylon)

.L00

This trolley is used for carrying flat cable for electrical power supply and can be adapted for hoses and round cables.

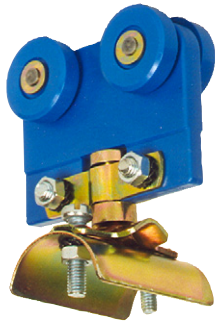

23.L00



25-27.L00

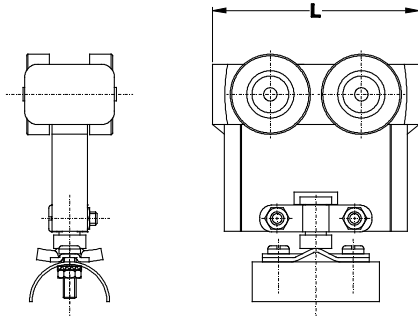

NIKO Profile No.	21.000	23.000	24.000	25.000	26.000	27.000
Cable trolley No.	23.L00		25.L00		27.L00	
For cable dimensions	flat up to 23x10mm & round up to 15mm diameter		flat up to 23x10mm & round up to 15mm diameter		flat up to 23x10mm & round up to 15mm diameter	
L (mm)	60		80		80	

## Cable Trolley (nylon)

.L01

The cable trolleys are used in electric operated systems for the transport of flexible cables from the fixed power supply to the machine or electric hoist.

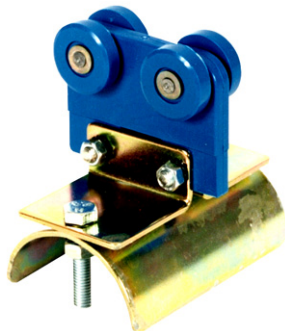

23.L01

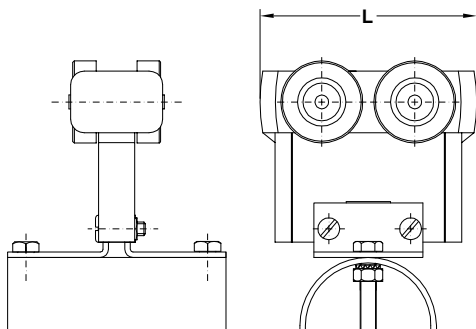

NIKO Profile No.	21.000	23.000	24.000	25.000	26.000	27.000
Cable trolley No.	23.L01		25.L01		27.L01	
For cable dimensions	flat up to 55x20mm		flat up to 55x20mm		flat up to 55x20mm	
L (mm)	60		80		80	



## Track End Stop

**.X01**

The end stop with a rubber buffer is positioned at the end of the open profiles. Used in conjunction with a fixed cross bolt.

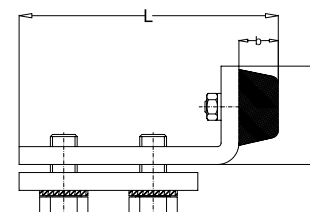
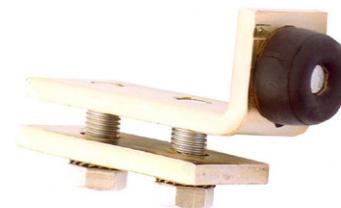

NIKO Profile No.	23.000	24.000	25.000	26.000	27.000
Item Ref	23.X01	24.X01	25.X01	26.X01	27.X01
L (mm)	73	87	122	145	145
h (mm)	24	30	45	55	77
b (mm)	10	10	22	22	22

## Track End Stop

**.X04**

NIKO Profile No.	21.000
Item Ref	21.X04
L (mm)	25
H (mm)	23
b (mm)	6

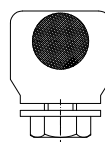
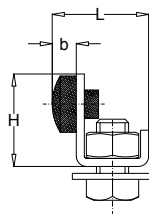

## Cable End Clamp

**.K00/.K02**

This item is used as an end stop and cable end clamp combined. It is installed at the power source end of the track.

NIKO Profile No.	23.000	24.000	25.000	26.000
Item Ref	23.K00	24.K00	25.K00	26.K00

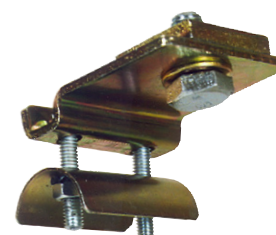

NIKO Profile No.	23.000	24.000	25.000	26.000
Item Ref	23.K02	24.K02	25.K02	26.K02

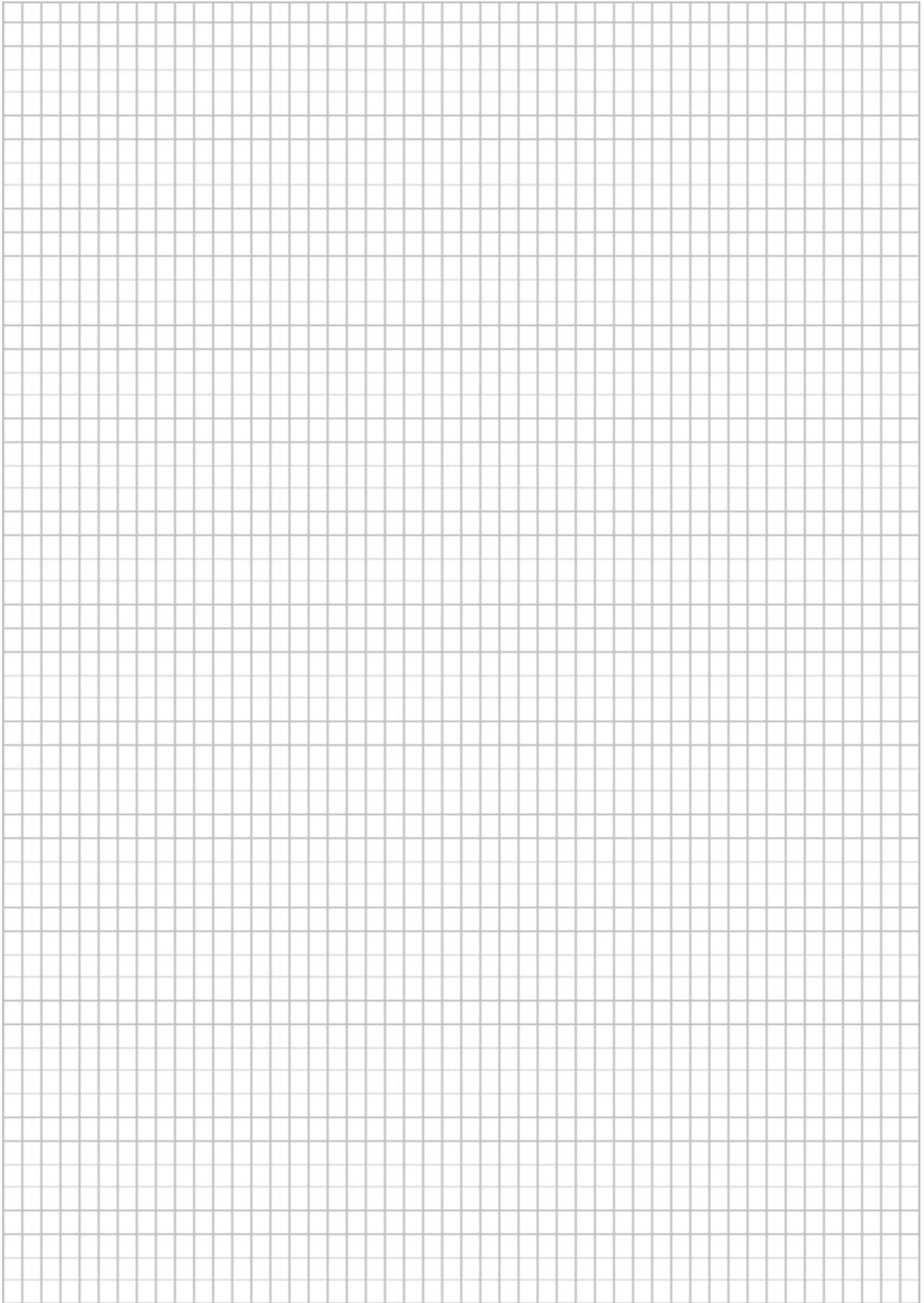

# Notes

A large, empty grid of small squares, intended for taking notes. The grid is composed of approximately 30 columns and 60 rows of squares.

Our quality control department is manned by experienced and highly skilled engineers. Our test lab is equipped with endurance test stands, tensile stress equipment, hardness test machines and other laboratory equipment. Finite Element Analysis is also performed during the developing phase of every component.

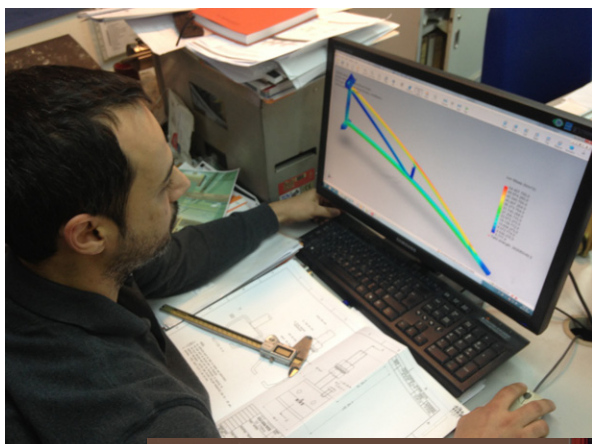

CABLE TROLLEYS AND FESTOON SYSTEMS





**AUSTRIA-NIKO Vertriebs GmbH**  
 Hainfelderstraße 3  
 A – 2564 Weissenbach  
 Tel. 0043 (0) 2674 81005  
 Fax 0043 (0) 2674 81006  
 office.at@niko.eu.com

**CHINA-NIKO China**  
 Room 605, Building 8, No.335  
 Jinian Road, Hongkou District,  
 200434 Shanghai  
 Tel. 0086 139 1814 5645  
 info.cn@niko.eu.com

**GERMANY-NIKO Technik GmbH**  
 Robert-Bosch-Strasse 14  
 D - 42489 Wuelfrath  
 Tel. 0049 (0) 2058 9093603  
 Fax 0049 (0) 2058 9093604  
 office.de@niko.eu.com

**GREECE-Helm Hellas S.A.**  
 82<sup>nd</sup> Km Athens-Korinthos  
 P.O. Box 209  
 201 00 KORINTHOS  
 Tel. 0030 (0) 27410 85803-6  
 Fax 0030 (0) 27410 25368  
 info@niko.eu.com

**POLAND- NIKO Polska**  
 Wojska Polskiego 97  
 Wielun 98-300  
 Tel. 0048 504 00 35 56  
 info.pl@niko.eu.com

**UNITED KINGDOM-NIKO Ltd**  
 Units 15-21, Insight Business Park  
 Welsh Road East, Southam  
 Warwickshire – CV471NE– UK  
 Tel. 0044 (0) 1926 813111  
 Fax 0044 (0) 1926 815599  
 Sales@niko-ltd.co.uk

**USA-NIKO Track**  
 300 Highpoint Ave  
 Portsmouth, RI. 02871 USA  
 Tel. 001 (0) 401 683 7525  
 Fax 001 (0) 401 683 6450  
 Sales@NikoTrack.com

**www.niko.eu.com**

Copyright NIKO ( Version June 2014)  
 We take no obligation for layout, composition, technical modifications as well as misprints.  
 Subject to technical modifications / images can be differ from original.

## TRADITION IS PROGRESS PRESERVED, PROGRESS IS TRADITION CONTINUED.

*Helm Hellas 1972 – 2012*

A family business for 40 years, Helm Hellas has been built on the twin foundations of Tradition and Progress, always heading towards a successful economic future.

## QUALITY IS THE RESULT OF ATTENTION TO DETAIL.

Quality will always be as standard for us, our products, our staff and our partners.

## OUR VISION.

We are an international company and our goal is to be market leaders in each of our business sectors.

## OUR VALUES

- ✓ We want to offer our customers the best quality at a reasonable price.
- ✓ We strive for continual improvement in our quality procedures – because we believe the company that doesn't move forward will be left behind.
- ✓ We respond to any demand on the market with the ongoing development of new products.
- ✓ We support our co-workers by ensuring they are highly motivated and well qualified.
- ✓ We want to expand into new sales markets to continue to win satisfied customers.



Your **NIKO** agent will be happy to advise you:

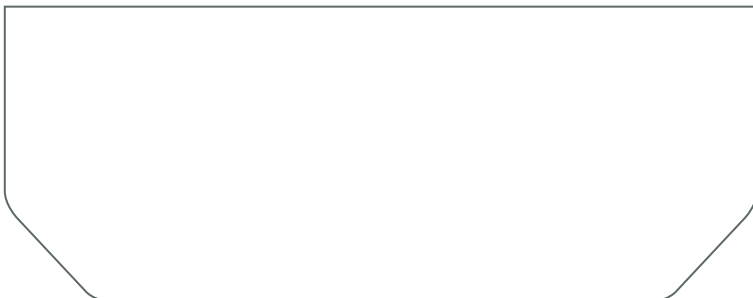

Complete product range **NIKO**:

- A1 – Residential Sliding Door Hardware
- A2 – Sliding Curtains Hardware
- B1 – Heavy Duty Sliding Door Hardware
- B2 – Folding and Harmonica Door Hardware
- B3 – Garage Door and Door around the corner Hardware
- C1 – Overhead Conveyor Systems
- C2 – Light Cranes
- C3 – Cable Trolleys and Festoon Systems
- C4 – Personal Fall Arrest Systems (EN 795)
- D – Sliding Gate Hardware